

Parts

- A.** 1 x 60mm Pole
- B.** 1 x Base Plate
- C.** 2 x Banner Arms
- D.** 2 x Pole Brackets
- E.** 2 x Screw Assembly

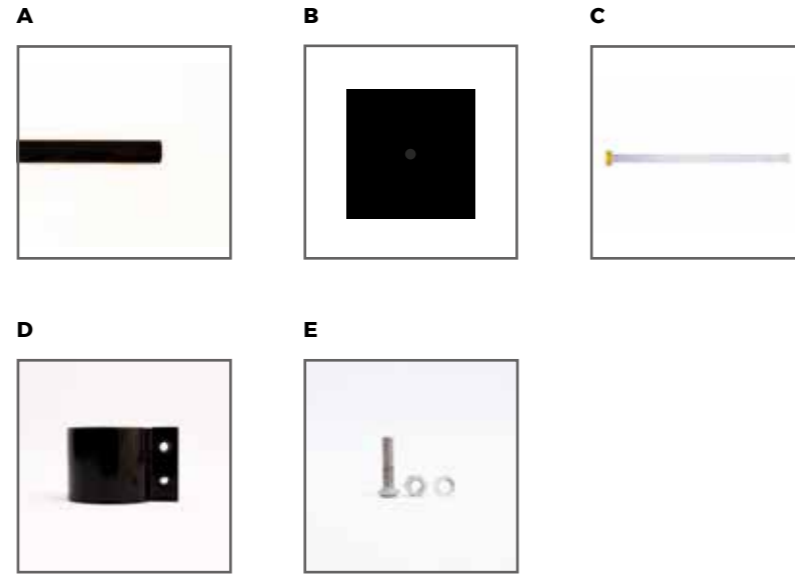

Technical Data - Overhead Mile Marker

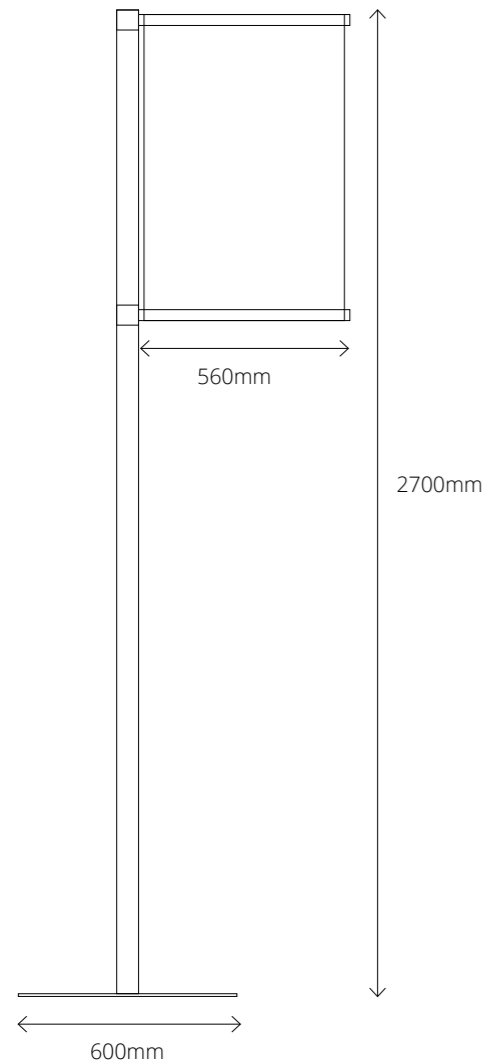

- Time Required**
< 15 mins
- People Required**
1 person
- Tools Required**
Hex Key,
Adjustable Spanner

HARRISON
FLAGPOLES | EDS | CREATIVE

Assembly

Slide the two pole brackets down the pole, position one flush to the top. The other can be positioned later.

1



Slot the banner support arm into the bracket, locating the holes. Ensure the lip on the top banner is facing upwards.

2

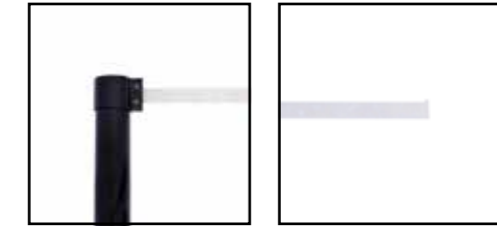

Secure the top banner arm support using the screw and washer supplied.

3



Slide the graphic onto the banner arm through the sleeve. To secure the banner, slide the remaining banner arm through the bottom sleeve, pull down and locate the lower pole bracket. Tighten using the same method as above.

4



Place the pole into the base and secure with sandbags if required.

5

